



D-Series Engine Overspeed Shut Down Valves (Auto/Manual Spindle Types)

Selection, Application and Maintenance

Valve Numbers

**D92-AM D102-AM
D121-AM D136-AM**

DESCRIPTION

A range of spring loaded poppet valves designed to automatically stop an engine by closing down the air intake should excessive overspeeding occur. Fitted with manual stop pull cable.

The closing force on the valve is provided by the intake air flow passing through. As the air flow increases, the closing force builds up. This is resisted by the valve spring force, the pre-load of which is adjustable such that at a given air flow the resulting force overcomes the spring resistance and causes the valve to close. Once closed the valve will not reset to the open condition until the engine stops.

This type of valve may be fitted to either naturally aspirated or turbocharged engines. It should be noted however that for a given valve setting the repeatability of the actual automatic shut down speed has a greater scatter in the case of a turbocharged engine. However, unless for special reasons a precisely repeatable shut down speed is required, adequate protection from excessive overspeed and potential resulting damage is still achieved.

The basic dimensions for this family of valves are tabulated below

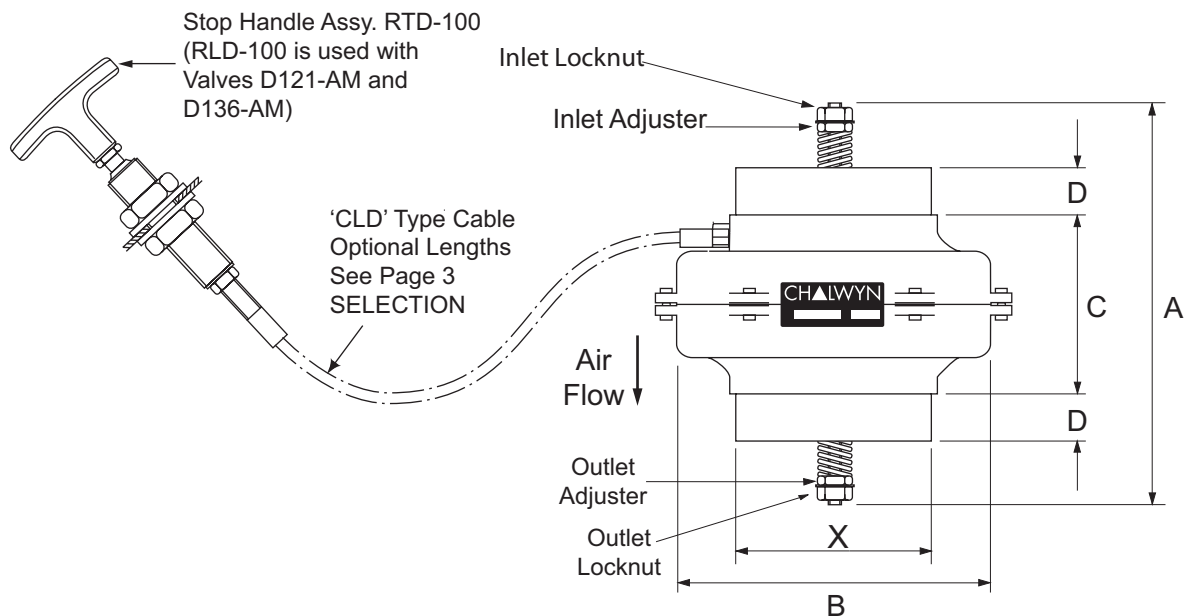

Valve Type	A mm	B mm	C mm	D mm	WEIGHT (valve only) kg
D92-AM	253	162	136	25	2.0
D102-AM	253	177	132	25	2.4
D121-AM	310	210	150	25	3.6
D136-AM	310	240	160	25	4.7

Outside diameter 'X' is selected to suit the size of the engine air intake hose - see page 3 'SELECTION'

Notes:

- * For smaller valve sizes see Chalwyn "Mini Range" and "Bendix Valves", data sheets CE 209 and CE207.
- * For larger valve sizes see "D200" valve data sheets CE 231.

SELECTION

Determine the rating of the engine to which the valve is to be fitted. Using the table below identify which valve(s) would be suitable. Finalise the selection by identifying the valve which can also be supplied with end diameters "X" to match the bore of the engine air intake hose at the position the valve is to be fitted. Note, end diameters are manufactured to the nearest 1mm. Generally, where more than one valve meets all requirements, select the larger valve size to minimise engine air intake restriction.

Valve Selection chart in Metric Units

Valve Type	Engine Power at rated Speed kW	Engine Air Intake Hose Bore mm	
		Minimum	Maximum
D92-AM	80 to 101	76	115
D92S-AM	102 to 190	76	115
D102-AM	100 to 123	89	115
D102S-AM	124 to 250	89	115
D121-AM	130 to 158	101	140
D121S-AM	159 to 321	101	140
D136-AM	150 to 188	126	154
D136S-AM	189 to 392	126	154

Valve Selection chart in Non-metric Units

Valve Type	Engine Power at rated Speed hp	Engine Air Intake Hose Bore inches	
		Minimum	Maximum
D92-AM	107 to 135	3	4 ½
D92S-AM	136 to 255	3	4 ½
D102-AM	134 to 165	3 ½	4 ½
D102S-AM	166 to 335	3 ½	4 ½
D121-AM	174 to 212	4	5 ½
D121S-AM	213 to 430	4	5 ½
D136-AM	201 to 252	5	6 ⅙
D136S-AM	253 to 525	5	6 ⅙

NOTE: Engine power is obtained using mathematical calculations for standard applications.
Air velocity may vary by intake hose configurations.
Valves should be sized as close to the middle of the range as possible.

Selection Chart - Cable

Select the required length of the manual shut down cable from the table. Alternative lengths may be available on request.

CABLE PART N°	LENGTH (metres)
CLD-100	1.0
CLD-150	1.5
CLD-200	2.0
CLD-300	3.0

FITTING

1. Chalwyn auto/manual shut down valves are supplied complete with the manual stop cable and 'T' handle fitted and adjusted. Do not separate the cable from handle or valve (see paragraph 8).
2. The shut down valve is designed for fitting as close to the engine air intake manifold as possible. Where an engine air intake flametrap is also fitted, the Chalwyn valve must always be positioned on the upstream (air cleaner) side of the flametrap. These same requirements are generally applicable to both naturally aspirated and turbocharged engines, but in the case of a turbocharged engine the following may be applicable:
 - a) Insufficient space to fit between the turbocharger and engine. In the case the valve may be fitted upstream of the turbocharger.
 - b) The turbocharger air outlet temperature is exceptionally high (200°C plus). In this case fit the valve downstream of the intercooler or upstream of the turbocharger.

Note: Where the valve is fitted immediately upstream of the turbocharger, ensure that the valve spindle does not project into the turbocharger when the valve closes.

3. Where more than one Chalwyn valve is fitted to an engine as in the case of an engine with multiple intake pipes, a balance pipe arrangement must be installed to connect the various intake pipes together downstream (engine side) of the shut down valves. Typically balance pipe diameters should be about 30% of the diameter of the intake pipes.
4. When fitting, ensure the direction of air flow is in compliance with direction indicated on the body. The valve may be installed either horizontally or vertically. Ensure that the manual shut down cable can be installed without tight bends and can be positioned to avoid mechanical damage or damage from hot surfaces.
5. The flexible cuffs at the inlet and outlet of the valve should be of a re-inforced type, provide adequate support for the valve and prevent excessive vibration. If necessary, additional support brackets mounted from the engine should be considered.
6. Particular care must be taken to ensure the integrity of the intake pipework between the Chalwyn valve and intake manifold. Ideally metal pipework should be used and any gaps kept as short as possible, (taking into account any relative movement)

and closed by re-inforced hose. The possibility of a hose collapse on closure of the shut down valve should be avoided.

7. Any engine crankcase breather connections into the intake system between the Chalwyn valve and engine, or any internal crankcase breather arrangement venting directly into the engine intake ports, must be sealed and replaced by an external breather system venting either to atmosphere or to the intake system upstream of the shut down valve. External breather system kits for various engine types are available from Chalwyn.
8. Fit the 'T' handle assembly RTD-100 through a suitable Ø20mm (3/4"dia) hole in a bulkhead or mounting bracket as follows. Release the handle locknut. Remove the handle, handle locknut and upper locknut and washer. Thread handle body through the bulkhead/bracket. Refit upper locknut and washer. Adjust lower and upper locknuts to position handle and tighten. Refit handle locknut and handle. Tighten locknut. (Note, alternative handle assembly RLD-100 is supplied with valve types D121S-AM and D136S-AM).

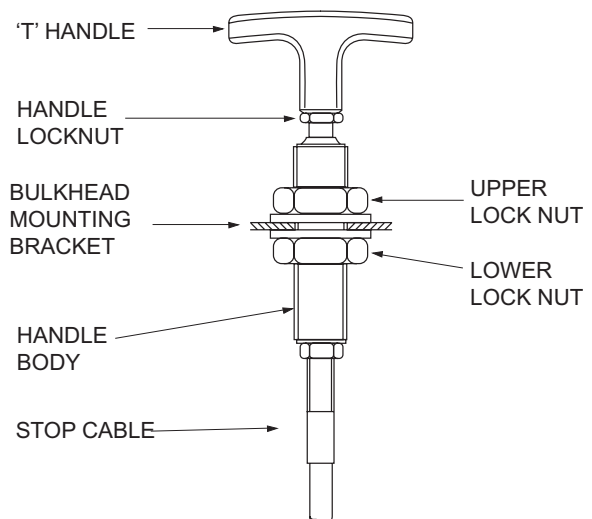

Note: On larger spindle valves it requires significant force to move the valve to the fully closed position using the RTD-100 handle whilst the engine is not running. This is a design feature and adjustment is not necessary. When the engine is running, manual shut down will be achieved satisfactorily using considerably less force to operate handle RTD-100.

ADJUSTMENT

Once the Chalwyn valve is installed, adjustment of the overspeed trip setting is carried out using the adjuster and locknut (refer to diagrams). Basically rotating the adjuster clockwise will increase the engine speed at which automatic shut down occurs.

As supplied, the valve will be adjusted such that shut down will generally occur well below the engine high idle speed. To increase the speed at which automatic shut down occurs, proceed as follows:

1. Check that the manual shut down cable is in the run condition i.e. the 'T' handle is pushed inwards.
2. Start engine. Slowly accelerate. Note speed at which shut down occurs.
3. Remove hose at **air inlet** to Chalwyn valve to expose the adjuster and locknut (see diagram).
4. Release locknut. Turn adjuster clockwise one turn. Tighten locknut.
5. Refit inlet hose to valve.
6. Start engine. Slowly accelerate. Note speed at which shut down occurs.
7. Repeat steps '3' to '6' until the first setting at which the engine does not shut down at high idle speed (i.e. full throttle, no load). Then either:
 - a) **Use the results of shut down speed versus adjuster setting as a calibration check to make a final adjustment to give the required setting (typically 10% to 15% over high idle). or**
 - b) **If a very precise setting is not required, turn the adjuster a further one turn clockwise to take the shut down above high idle speed by a suitable margin. When using this setting procedure it may be found that the engine occasionally shuts down during the normal operation. If so, turn the adjuster clockwise by a further one half turn.**
8. Ensure the adjuster locknut is fully tightened. (Use a thread lock adhesive on the locknut threads).

Notes:

Insufficient Adjustment

Should there be insufficient adjustment available to set the required overspeed trip point, the outlet locknut should be released and the outlet adjuster rotated anticlockwise by four turns. The outlet locknut should then be treated with a thread lock adhesive and securely tightened. Further adjustment to the inlet adjuster as per above instructions is then continued

Turbocharged Engines

When setting up a valve on a turbocharged engine using the preceding method, it may be found that at high power outputs, the engine will shut down at a lower speed than required. If this occurs, further small adjustments in steps of one half turn clockwise should be made until the problem is eliminated

MAINTENANCE

Routine maintenance should be undertaken as below:-

Daily: Run engine at a mid range speed. Check satisfactory shut down occurs when the manual emergency stop lever is operated.

Three Monthly:

1. Disconnect intake pipework and release the valve from any support brackets etc. to allow it to be removed.
2. Inspect the valve internally for cleanliness. If necessary, clean in paraffin or white spirit taking normal precautions. Dry the valve thoroughly.
3. Check there is no excessive wear and that the valve moves smoothly over its complete operating stroke. **DO NOT LUBRICATE.**
4. Refit valve. Check valve setting based on the "Adjustment" instructions given herein.
5. With the engine running at medium speed pull the manual stop handle. The engine should come to a complete stop within a few seconds.

Important Notes:

The three monthly routine maintenance period requirement is dependent on the operating conditions to which the equipment is exposed and, by experience, may need to be varied.

Any maintenance problems not covered by the routine maintenance schedule should be discussed with your Chalwyn Distributor before any repair work is undertaken.

CHALWYN

by AMOT

Chalwyn by AMOT
sales@chalwyn.co.uk
www.chalwyn.com

A division of Roper Industries Limited

UK

Western Way
Bury St Edmunds
Suffolk, IP33 3SZ
Tel: +44 (0)1284 715739
Fax: +44 (0)1284 715747

USA

8824 Fallbrook Drive
Houston
TX 77064
Tel: +1 281 940 1800
Fax: +1 713 559 9419

Canada

3230 97 Street
Edmonton
Alberta, T6N 1K4
Tel: +1 780 465 4429
Fax: +1 780 469 6275

Chalwyn's Quality Management
System is approved by LRQA.

